

**DC-TO-AC INVERTER**  
**MODEL 1716-36RR-120-60**  
**USER'S INFORMATION**



MODEL 1716-36RR-120-60

DC-TO-AC INVERTER

USER'S INFORMATION

All information contained in this document is the property of Wilmore Electronics Company, Inc. The providing of this document to any person or organization external to Wilmore shall in no way be construed as a license or as permission to use this information for any purpose other than to facilitate the use and maintenance of Wilmore equipment.

WILMORE ELECTRONICS COMPANY

P.O. Box 1329

Hillsborough, N.C. 27278

Telephone: (919) 732-9351

Fax: (919) 732-9359

[www.wilmoreelectronics.com](http://www.wilmoreelectronics.com)

## **WARNING - DANGER OF ELECTRIC SHOCK!**

**Hazardous voltages can be present on the front-panel wiring terminals and receptacles. Disconnect the DC input power at the source end of the input cables before working near the front panel.**

**The installer should read all of Section II (Installation and Operation) and refer to Figure 1 for additional information BEFORE MAKING ANY CONNECTIONS TO THE INVERTER.**

## **CAUTION - TO AVOID EQUIPMENT DAMAGE DURING INSTALLATION...**

**Prior to installing the inverter, verify that its front-panel input power switch (a “rocker-arm” circuit breaker) is in the OFF position, indicated by a wedge-shaped section of the rocker arm protruding from the front panel and exposing white plastic in the rocker assembly. If the inverter does not appear to be turned off, push against the word “OFF” printed on the switch face to expose the white plastic indicator before making any connections to the inverter.**

**...DO NOT “HOT PLUG” OR APPLY AN ENERGIZED  
CONNECTION TO A “TURNED ON” INVERTER!**

## I. GENERAL DESCRIPTION

The Model 1716-36RR dc-to-ac inverters provide an isolated, regulated, 120-Vac, 60-Hz output from nominal 36 Vdc vehicle battery systems aboard locomotives and rail vehicles. The operating input voltage range is 25 to 45 Vdc. The output-voltage waveshape is a three-level stepped approximation to a sine wave with peak, average and rms values approximating those of a sine wave. Maximum rated output power is 250 volt-amperes (continuous duty rating at 50°C ambient temperature and free-air convection cooling). The dc input and the ac output are isolated from the chassis and from each other. Isolation capable of passing a 1500 Vdc “hipot” test is provided between the input and output and between the input and chassis.

This inverter is electronically protected against output overloads and short circuits. Recovery to normal inverter operation is automatic upon removal of the fault. A front-panel circuit breaker provides protection against accidental reversal of input polarity during installation.

## II. INSTALLATION AND OPERATION

Before making connections and powering up the inverter, it is suggested that the installer read all of Section II, and refer to Figure 1 for additional information.

Connection and operation of Series 1716-36RR inverters are almost entirely self-explanatory from the front panel markings on each unit. A combination circuit breaker and ON/OFF switch is provided on the front panel for **DC INPUT** power. Its rocker handle is flush with the front panel while in the ON position to guard against unintentionally turning the circuit breaker OFF through incidental contact. The **DC INPUT** power connections are made via a two-part (i.e. header and plug) connector. Input cabling can be connected to the inverter without separating the plug from the header. Alternately, the plug may be removed from the inverter by disengaging its mounting-flange screws, and the cabling can be connected to the plug prior to re-engaging it with the header on the inverter’s front panel (be sure to re-engage the mounting-flange screws as well). The positive and negative terminals on the connector are clearly marked, and deliberate caution should be exercised to avoid polarity mistakes. To connect the power cables, simply strip 3/8” – 1/2” from one end of each cable and insert into the appropriate connector wire clamp. Tighten the wire-clamp screw securely and, if using stranded wire, check to make sure that all wire strands have been captured by the wire clamp.

Suggested wire sizes for dc-input cabling is #14AWG. It is desirable that these cables be kept as short as possible, and, if their length must exceed 10 feet, it may be desirable to use larger diameter (lower gauge) cables.

Note that these inverters are constant-output-power devices, i.e., with a constant output load, the dc-input current and dc-input voltage are inversely proportional. This means that the maximum input current is drawn at the minimum input voltage.

The **AC OUTPUT** receptacles provide power to the user's load. The **CHASSIS GROUND** screw provided on the front panel is electrically common with the ground connection on the AC OUTPUT receptacle.

FIGURE 1. FRONT PANEL

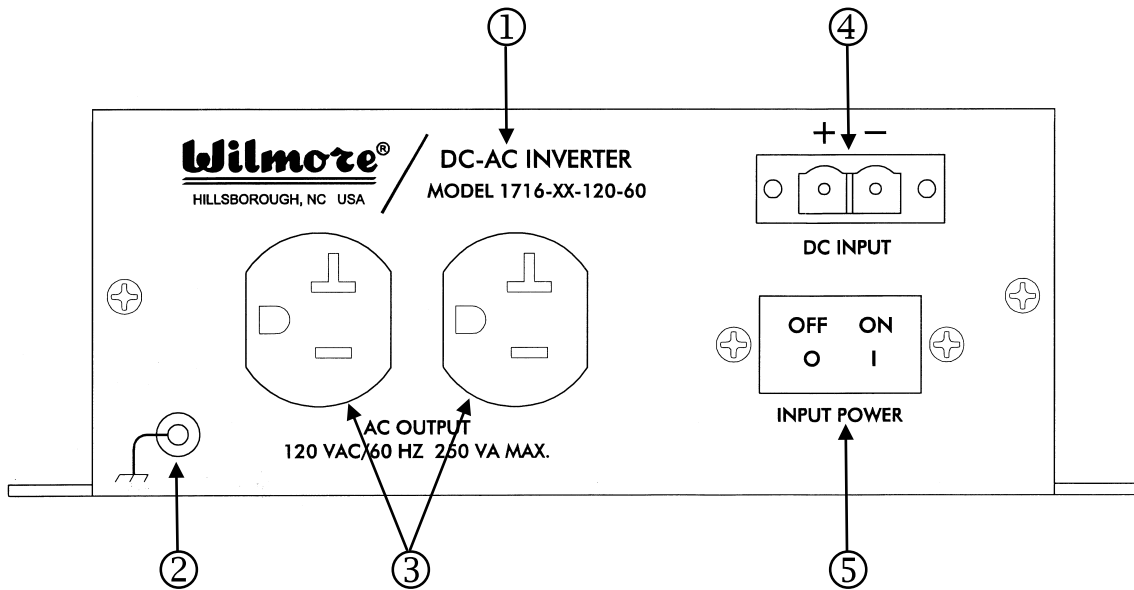

- ① **MODEL NUMBER:** This is the complete model number of the inverter, including any standard or special factory-assigned modification codes.
- ② **CHASSIS GROUND TERMINAL:** Connection to chassis ground is provided for use with #8 hardware
- ③ **AC OUTPUT RECEPTACLES:** These receptacles are standard two NEMA type 5-20R receptacles. The load at these receptacles should not exceed the power rating of the inverter.
- ④ **DC INPUT TERMINALS:** Connections for DC input power are provided via a two-part (plug and header) connector, which accommodates appropriate wire sizes. Please refer to Section II for recommended wire sizes for this inverter.
- ⑤ **DC INPUT CIRCUIT BREAKER:** This is a combination DC input switch and circuit breaker, provided in the positive (+) input line.

### III. MAINTENANCE INFORMATION

Other than preventing dust and debris accumulation on external surfaces of the inverter, no periodic maintenance should be required.

A damaged or malfunctioning unit should be returned to Wilmore for repair. Multiple-component cascade failures in power conversion circuitry can greatly complicate trouble-shooting procedures, and factory technicians familiar with the circuitry can locate the problem quickly, explore adjacent circuitry for stressed or damaged components, and subject the inverter to a thorough retest.

Wilmore maintains a **Return Material Authorization** system in order to efficiently track your inbound shipment and expedite its repair and return to you. Before shipping material for repair to Wilmore, please call (919) 732-9351 or fax (919) 732-9359 and request an **RMA Number** for your shipment. If possible, please provide the complete model number of the equipment, its serial number, and a brief description of the problem. Place this **RMA Number** on the outside of the package and ship prepaid to:

WILMORE ELECTRONICS CO., INC.

607 U.S. 70A East

P.O. Box 1329

Hillsborough, NC 27278

## LIMITED WARRANTY

Wilmore Electronics Company, Inc. warrants this product to be free from defects in material and workmanship for one (1) year after delivery to the original purchaser. During this period, a defective product for which an authorization to return the product has been given, shall be returned to Wilmore freight prepaid. The products will be repaired, replaced, or credit allowed only if the defect, after examination by Wilmore, is determined to be a defect in material or workmanship. If this returned product is determined by Wilmore to have suffered from user misuse or abuse or to have been opened or modified without written instructions from Wilmore, or if the date of receipt of a request for return authorization exceeds the 1-year warranty period, the warranty is null and void. In such cases, Wilmore will determine the cost of repair, quote this price to the purchaser, and continue as advised by the purchaser.

The sole obligation of Wilmore and the purchaser's exclusive remedy under this or any other warranty, expressed or implied, is the repair or replacement of a defective product as provided above, or the issuance of credit in an amount not to exceed the contract price for the product deemed to be defective. Wilmore makes no warranty of merchantability or fitness for a particular use. Wilmore shall not be responsible for incidental or consequential damage, whether or not foreseeable, caused by defects in this product. There are no other warranties which shall extend the description above.