

## **DC-TO-AC INVERTER**

**1747-24-115-60**

**1747-48-115-60**

**1747-130-115-60**

**1787-24-115-60**

**1787-48-115-60**

**1787-130-115-60**

## **USER'S INFORMATION**



SERIES 1747 and 1787  
2,200-VA DC-TO-AC INVERTER  
USER'S INFORMATION

This User's Information manual is applicable for the following Models:

1747- <del>24</del> -115-60	1787- <del>24</del> -115-60
1747- <del>48</del> -115-60	1787- <del>48</del> -115-60
1747- <del>130</del> -115-60	1787- <del>130</del> -115-60

All information contained in this document is the property of Wilmore Electronics Company, Inc. The providing of this document to any person or organization external to Wilmore shall in no way be construed as a license or as permission to use this information for any purpose other than to facilitate the use and maintenance of Wilmore equipment.

WILMORE ELECTRONICS COMPANY  
607 U.S. 70A East  
P.O. Box 1329  
Hillsborough, N.C. 27278

Telephone: (919) 732-9351

Fax: (919) 732-9359

[www.wilmoreelectronics.com](http://www.wilmoreelectronics.com)

**Note for Series 1787 only:**

This User's Information manual provides general guidance regarding the installation and operation of this dc-to-ac power inverter, along with maintenance, warranty and contact information. It does not discuss features, programming and connectivity of the inverter's Network Communications Interface. For complete information on the setup and use of this feature...

Please Download the  
INVERTER NETWORK COMMUNICATIONS  
INTERFACE User's Information Manual at

<https://www.wilmoreelectronics.com/support/downloads.html>

(Simply locate the appropriate model number for this inverter from the list and select it.)

## **WARNING - DANGER OF ELECTRIC SHOCK!**

Hazardous voltages can be present on the rear-panel wiring terminals and receptacles. Disconnect the DC input power at the source end of the input cables before working near the rear panel.

The installer should read all of Section II (Installation and Operation) and refer to Figures 1 & 2 for additional information **BEFORE MAKING ANY CONNECTIONS TO THE INVERTER.**

## **CAUTION - TO AVOID EQUIPMENT DAMAGE DURING INSTALLATION...**

Prior to installing the inverter, verify that its front-panel input power switch (a “rocker-arm” circuit breaker) is in the OFF position, indicated by a wedge-shaped section of the rocker arm protruding from the front panel and exposing white plastic in the rocker assembly. If the inverter does not appear to be turned off, push against the word “OFF” printed on the switch face to expose the white plastic indicator before making any connections to the inverter.

**...DO NOT “HOT PLUG” OR APPLY AN ENERGIZED  
CONNECTION TO A “TURNED ON” INVERTER!**

MODEL 1747 and 1787 DC-TO-AC INVERTER

USER'S INFORMATION

TABLE OF CONTENTS

- I. General Description
- II. Installation and Operation
- III. Front-Panel Controls and Indicators
- IV. Rear-Panel Wiring Connections and Information
- V. Maintenance Information
- VI. Warranty Statement

## I. GENERAL DESCRIPTION

The Series 1747 and 1787 dc-to-ac inverters provide a regulated, 115-Vac, frequency-stable 60-Hz sine-wave output from station batteries and other widely-fluctuating battery systems. Maximum rated output power is 2,200 volt-amperes (continuous duty rating at 50°C ambient temperature). The dc input and the ac output are galvanically isolated from the chassis and from each other.

This inverter is electronically protected against short-term output overloads, and recovery to normal inverter operation is automatic upon removal of the fault. Protection against a *sustained* output overload fault is provided by an output circuit breaker located on the right side of the front panel. An input power circuit breaker located on the left side of the front panel provides protection against accidental reversal of dc-input polarity during installation.

A Network Communications Interface (available only on Series 1787) allows the user to monitor several key aspects of the inverter's operation via a web interface, SNMP (Simple Network Management Protocol), or serial terminal port (see the separate Inverter Network Communications Interface user's information manual for additional information, available from Wilmore's website at <http://www.wilmoreelectronics.com/support/downloads.html> )

## II. INSTALLATION AND OPERATION

### **WARNING – DANGER OF ELECTRIC SHOCK**

**Hazardous voltages can be present on the rear-panel wiring terminals and receptacles. Disconnect the DC input power source end of the input cables before removing the rear cover panel to access wiring terminals. Prior to making any wiring connections to the inverter, read all of Section II, and refer to Figures 1 and 2 for additional information. Upon completion of input wiring, replace rear cover panel before energizing DC input.**

Connection and operation of Series 1747 and 1787 inverters are almost entirely self-explanatory from the front and rear panel markings on each unit.

### **REAR PANEL CONNECTIONS**

#### **CAUTION**

**To avoid equipment damage during installation...**

1) Prior to installing the inverter, verify that its **DC INPUT** and **AC OUTPUT** circuit breakers (located on the front panel) are both in the "OFF" position.

2) Safe installation practice dictates that the DC input line connections should be de-energized at the DC source prior to connecting to the inverter input. Verify that this is the case before making any connections to the inverter. Once these input connections are made and the inverter's **DC INPUT** and **AC OUTPUT** circuit breakers have been verified to be in the "OFF" position, the DC input lines can be energized.

3) Once the DC input lines have been energized (both front-panel circuit breakers still in the "OFF" position), power up the inverter by switching the **DC INPUT** circuit breaker to the "ON" position. Allow the front panel meter to stabilize (3 to 5 seconds) before switching the **AC OUTPUT** circuit breaker to the "ON" position.

**... do not "hot plug" or apply an energized DC input connection to a "turned on" inverter.**

To access the DC-input connections, remove the four #6 screws that secure the cover panel to the inverter rear panel. The positive and negative compression terminals labeled **DC INPUT** are clearly marked, and deliberate caution should be exercised to avoid polarity mistakes. The suggested wire sizes for input cabling are shown in the following chart. It is desirable that these cables be kept as short as possible, and, if their length must exceed 10 feet, it may be desirable to use larger diameter (lower gauge) cable.

Model Number	Input Voltage Range (Vdc)	Input Current (A <sub>dc</sub> )*	Suggested Cable (AWG)
1747/1787- <b>24</b> -115-60	21-29	119	#2
1747/1787- <b>48</b> -115-60	42-58	58	#6
1747/1787- <b>130</b> -115-60	105-145	23	#8

\*Typical at full load and minimum input voltage

Note that these inverters are constant-output-power devices, i.e., with a constant output load, the dc-input current and dc-input voltage are inversely proportional. This means that the maximum input current is drawn at the minimum input voltage.

The rear-panel **AC OUTPUT** receptacles and **CHASSIS GROUND** stud are clearly marked, and care should be taken to avoid wiring errors. The receptacles are NEMA type 5-20R. The chassis ground stud accepts lugs for use with #10 hardware.

Good installation practice for power conversion equipment dictates that an input fuse or circuit breaker should be located at the power-source end of the cables feeding the equipment. The type and rating of such devices are largely dependent on local and/or national codes and installation variables such as cable routing and wire gauge. Wilmore cannot anticipate these variables and consequently does not recommend specific fuse or circuit breaker values. However, it is important to note a few operating characteristics of this unit that may affect an installer's choice of protection devices.

1) As mentioned previously, this unit is a constant-power device; that is, it draws its maximum input current at its minimum input voltage.

2) As with essentially all electronic equipment with significant input capacitance, the unit will draw an initial peak current many times its normal operating current for a very brief period (a few milliseconds or so) when power is initially applied. Consequently, instantaneous-trip circuit breakers or non-time-delay fuses may be activated by normal power-up events and are not recommended.

3) This unit is capable of providing output current well beyond its continuous-duty rating for brief periods in order to power loads with high start/surge currents (e.g. small motors). Consequently, it will draw proportionately higher input current during such peak power demands, and the installer's choice of input protection devices should take this into account. Moreover, and even though the user's application may only require a fraction of its full power rating, the unit may briefly draw this higher current at start-up when the unit is charging its output filter capacitors and/or the load's input filter capacitors (effectively placing a temporary overload on the unit's output). This time period may be much longer than the few milliseconds required to charge the input capacitors as referenced in 2) above. If the user is experiencing nuisance circuit breaker or fuse operation at power-up, please contact Wilmore's customer service group to discuss information about your particular application:

Telephone: 919-732-9351

Email: [info@wilmoreelectronics.com](mailto:info@wilmoreelectronics.com)

## FRONT PANEL CONTROLS / INDICATORS

A combination circuit breaker and ON/OFF switch is provided on the front panel for **DC INPUT** power. In addition, a combination circuit breaker and ON/OFF switch is provided on the front panel for **AC OUTPUT** power for protection against a sustained output overload. Its rocker handle is flush with the front panel while in the ON position to guard against unintentionally turning the circuit breaker OFF through incidental contact.

**NOTE:** Before energizing the inverter with the DC Input Circuit Breaker, be sure the AC Output Circuit Breaker is OFF (load disconnected). Upon energizing the inverter, allow the front-panel meter to stabilize (3 to 5 seconds) before connecting the inverter output to the load by closing the AC Output Circuit Breaker.



## AC Panel Meter

The digital power meter on the front panel measures and displays the rms voltage and current, active (real) power and the power factor of the inverter's output.

### Basic Operation:

When powering up the inverter for the first time, the meter will perform a self-test routine and then continuously display the inverter's output, measured in ac volts. The display will remain in the **VOLTS** mode as long as the front panel **SEL** (Select) button is not touched.

After the unit powers up to normal operation in the **VOLTS** reading mode, momentarily (approximately one second) touching the **SEL** button three times in succession will cycle the display to **AMPS**, **WATTS**, and **PF** (Power Factor). Momentarily touching **SEL** a fourth time will return the display back to the **VOLTS** reading mode.

Holding the **SEL** button down for 3 seconds will place the unit in a continuous auto-cycling mode, and the display will repetitively scroll through all four measurements, with each measurement remaining displayed for 3 seconds.

When the continuous auto-cycling mode is initially selected, the meter will briefly display **Auto On** before continuous cycling begins. Momentarily touching the **SEL** button again will cause the unit to briefly display **Auto OFF** before it returns to the fixed **VOLTS** reading mode.

### Displaying a Specific Mode on Power Up:

The meter can be configured to automatically show any one of the four display modes upon future applications of ac power. For example, it may be desirable to configure the unit to always power up in the **AMPS** mode.

To set the unit to always read **AMPS** on power up, tap the **SEL** switch until the **AMPS** mode is displayed, and then leave the unit in this mode for at least 60 seconds. As long as the **SEL** switch is not pressed again during the 60 second interval, the unit will configure itself to always power up displaying the chosen mode, which is **AMPS** in this example.

This functionality also applies to the auto-cycle mode. That is, the unit can be configured to always power up in the auto-cycle (scrolling) display mode by following the instructions outlined above.

### III. FRONT-PANEL CONTROLS AND INDICATORS

**FIGURE 1. FRONT PANEL**

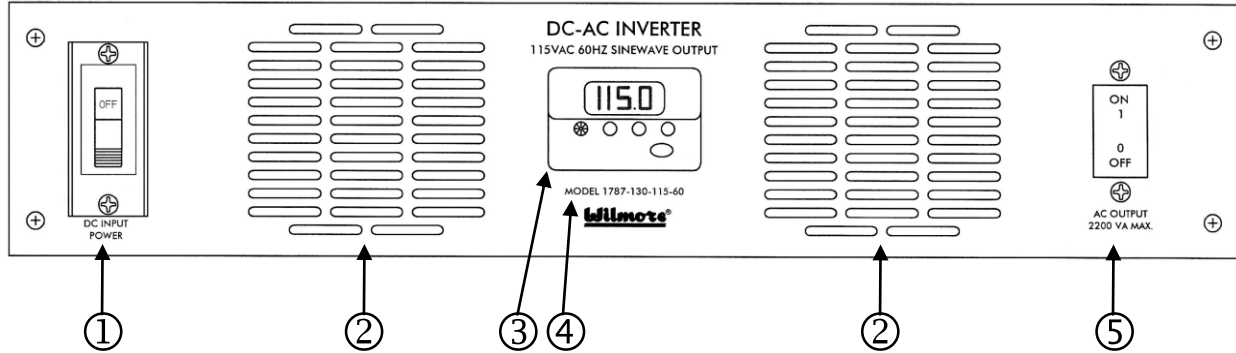

- ① **DC INPUT CIRCUIT BREAKER:** This is a combination DC input power switch and circuit breaker, provided in the positive (+) input line.
- ② **AIR INLETS:** These areas must be kept clear of any obstruction that might impede the free flow of air entering the unit. Internal fans draw cooling air from the front of the enclosure and exhaust air through vents on the rear panel.
- ③ **AC PANEL METER:** This provides various information on the inverter's output status. It can be set to continuously display any of the following: volts, amperes, watts, or power factor. The display can also be set to continuously auto-cycle between each of these. For additional information, see Section II.
- ④ **MODEL NUMBER:** This is the complete model number of the inverter, including any standard or special factory-assigned modification codes.
- ⑤ **AC OUTPUT CIRCUIT BREAKER:** This is a combination AC output power switch and circuit breaker.

#### IV. REAR-PANEL WIRING CONNECTIONS AND INFORMATION

**FIGURE 2. REAR PANEL (cover panel removed)**

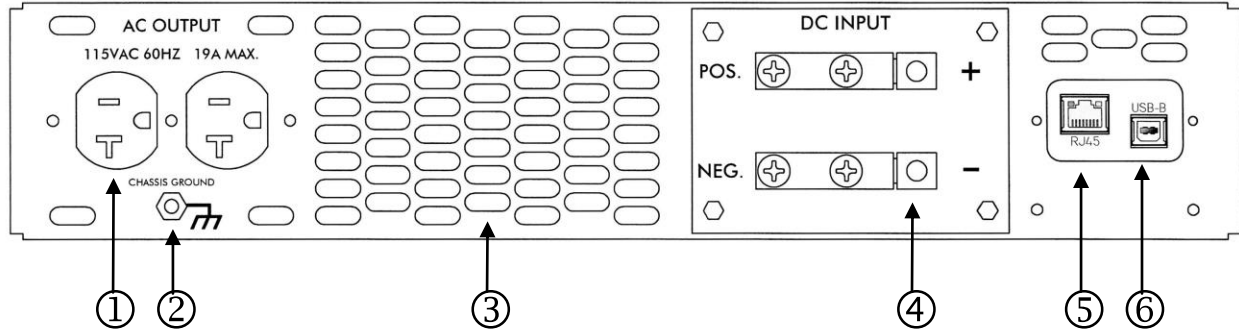

- ① **AC OUTPUT RECEPTACLES:** These receptacles are standard NEMA 5-20R three-prong receptacles. The combined load at these receptacles should not exceed the power rating of the inverter.
- ② **CHASSIS GROUND TERMINAL:** Connection to chassis ground is provided for use with #10 hardware.
- ③ **AIR OUTLETS:** These areas must be kept clear of any obstruction that might impede the free flow of air exiting the unit. Internal fans draw cooling air from the front of the enclosure and exhaust air through these vents.
- ④ **DC INPUT CONNECTOR:** Connections for DC input power are provided via compression lugs which accommodate appropriate wire sizes. Please refer to Section II for recommended wire sizes for this inverter.
- ⑤ **RJ45 ETHERNET PORT (Series 1787 only):** Used for network connectivity. A properly configured IPv4 Ethernet connection is required to access the web interface, monitor via SNMP (Simple Network Management Protocol), or query the web service API (Application Programming Interface). For additional information, see separate Inverter Network Communications Interface user's information manual, available from Wilmore's website as a download.
- ⑥ **USB 2.0 TYPE B PORT (Series 1787 only)::** Used for initial setup and configuration of the communications interface (requires Wilmore's configuration application). Also allows you to query specific information via the serial terminal console. See separate Inverter Network Communications Interface user's information manual, available from Wilmore's website as a download.

## V. MAINTENANCE INFORMATION

Other than preventing dust and debris accumulation on internal components and external surfaces of the inverter, no periodic maintenance should be required.

If a problem is encountered using the inverter, the user should first make sure that the problem is definitely within the inverter before returning it for repair. A visual check should be made of the input and output cabling, paying particular attention to the marked polarities. With the dc input circuit breaker off, but with the input voltage applied, measure the input voltage directly at the input terminals. Verify that the input voltage and polarity are as marked on the unit. Low output voltage may be the result of an output overload or an output cabling error.

A damaged or malfunctioning unit should be returned to Wilmore for repair. Multiple-component cascade failures in power conversion circuitry can greatly complicate troubleshooting procedures, and factory technicians familiar with the circuitry can locate the problem quickly, explore adjacent circuitry for stressed or damaged components, and subject the inverter to a thorough retest.

Wilmore maintains a **Return Material Authorization** system in order to efficiently track your inbound shipment and expedite its repair and return to you. Before shipping material for repair to Wilmore, please call (919) 732-9351 or email [info@wilmoreelectronics.com](mailto:info@wilmoreelectronics.com) and request an **RMA Number** for your shipment. If possible, please provide the complete model number of the equipment, its serial number, and a brief description of the problem. Place this **RMA Number** on the outside of the package and ship prepaid to:

WILMORE ELECTRONICS CO., INC.

607 U.S. 70A East

P.O. Box 1329

Hillsborough, NC 27278

## LIMITED WARRANTY

Wilmore Electronics Company, Inc. warrants this product to be free from defects in material and workmanship for one (1) year after delivery to the original purchaser. During this period, a defective product for which an authorization to return the product has been given, shall be returned to Wilmore freight prepaid. The products will be repaired, replaced, or credit allowed only if the defect, after examination by Wilmore, is determined to be a defect in material or workmanship. If this returned product is determined by Wilmore to have suffered from user misuse or abuse or to have been opened or modified without written instructions from Wilmore, or if the date of receipt of a request for return authorization exceeds the 1-year warranty period, the warranty is null and void. In such cases, Wilmore will determine the cost of repair, quote this price to the purchaser, and continue as advised by the purchaser.

The sole obligation of Wilmore and the purchaser's exclusive remedy under this or any other warranty, expressed or implied, is the repair or replacement of a defective product as provided above, or the issuance of credit in an amount not to exceed the contract price for the product deemed to be defective. Wilmore makes no warranty of merchantability or fitness for a particular use. Wilmore shall not be responsible for incidental or consequential damage, whether or not foreseeable, caused by defects in this product. There are no other warranties which shall extend the description above.